

Swan

ICE SHAVER

INSTRUCTION MANUAL

ELECTRIC TYPE

MODEL **SI-100E**

for Block Ice

We sincerely want to thank you for purchasing our Swan brand ice shaving machine. For correct use of the product, be sure to carefully read the instruction manual. Furthermore, after reading it, the manual should be kept in your file so you can read it again in case of necessity. In case the product is resold to another party, be sure it is sold together with the instruction manual.

WARNING

POTENTIAL RISK OF FIRE, ELECTRIC SHOCK AND PERSONAL INJURY EXISTS. CHECK WIRING AND SET PRONGS INTO ICE BLOCK FIRMLY TO AVOID INJURY.

**CAUTION-EXPOSED SHARP
OBJECTS INSIDE.**

CAUTION

Read the following instructions carefully before use. Do not fail to observe this.

- Children or person who do not thoroughly understand the product should not be allowed to use it.
- Use single phase 120V power source.
- Place the machine on a strong and flat horizontal surface or location where dripping water is of no problem.
- The blades as well as the spikes are very dangerous. They must be handled with extreme care.
- Place the block ice on center of the shaving disc with the flat side up and be sure the spikes on the block ice holder are deeply embedded in the ice before use. Imperfect placement or down pressure on the block ice will cause the ice to fly out which is extremely dangerous.
- Ice stored in refrigerator should not be used immediately for shaving, as it will damage the blade. Let the ice to thaw and become semi transparent before use.
- Do not pour water on the machine or dip it in water.
- As the cover of the product is made of plastic, do not place it where the product is exposed to direct sunlight or near heating equipment or use paint thinner or similar type of products to clean the cover as these products will disfigure the cover.

USING DIRECTION

1. Use machine on a firm stand or counter.
2. Replace or sharpen blade at least 2 or 3 times a season.
3. Lubricate Main Shaft from time to time.
4. Ice stored in refrigerator should not be sued immediately for shaving as it will damage the blad. Let the ice to thaw and become semi-transparent before use.

DIRECTIONS BEFORE USE

The Ice Block Holder Crank is detached from the machine and packed together so it must be installed.

- Insert Ice Block Holder Crank onto Shaft Pin located on the right side of machine, then firmly tighten screw in the center.

OPERATING DIRECTIONS

- 1 Turn Ice Block Holder Crank counterclockwise and raise Main Shaft Ice Block Holder. The Polycarbonate shield should be turned horizontally to the rear.

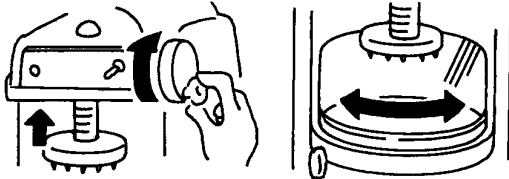

- 2 Place ice block flat side up on center of Shaving Disc.

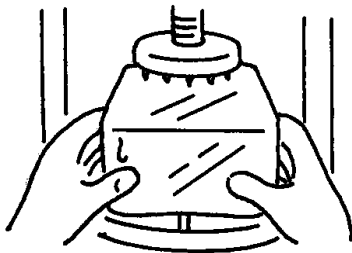

- 3 Turn Ice Block Holder Crank clockwise and lower Ice Block Holder onto ice. Apply pressure until the Ice Block Holder prongs are firmly imbedded in the ice. The polycarbonate shield should be turned horizontally to the front.

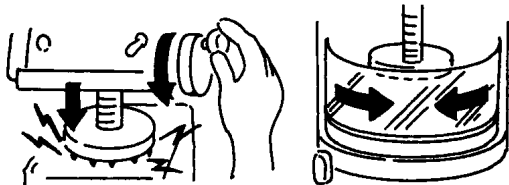

- 4 Turn on Motor Switch. Main Shaft Ice Block Holder will start to revolve.

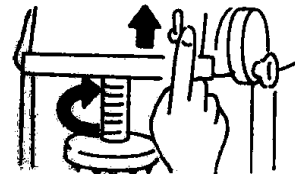

- 5 Turn Blade Adjustment Knob located on the left side of Shaving Disc Frame counterclockwise. This will raise the blade, allowing it to shave the ice. The higher the blade is raised, the coarser and faster the ice will come out.

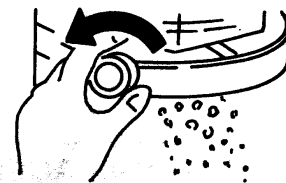

- 6 After the texture of shave ice is adjusted, hold the cone or cup under the outlet of shave ice.

- 7 Turn off Motor Switch after use.

- 8 Turn Ice Block Holder Crank counterclockwise and raise Main Shaft Ice Block Holder.

- 9 Remove ice block.

BLADE ADJUSTMENT

1. The Blade is recessed below the surface of the Shaving Disc when the Blade Adjustment Dial is turned to 0.
2. To raise the Blade, slowly turn the Blade Adjustment Know left.
3. Set the Blade Adjustment Dial on 1 for fine shaving and 6 for roughest shaving.
 - THE DIAL WILL INDICATE 0 WHEN THE BLADE ADJUSTMENT KNOW IS TURNED RIGHT ALL THE WAY AND STOPS.

BRAKE ADJUSTMENT

Adjust when shaving is unsatisfactory. (For others, see Trouble Shooting Guide.)

1. When the Ice Block Holder Crank turns very lightly, turn Brake Adjustment Screw clockwise with screw driver.
2. When the Ice Block Holder Crank turns very heavily, turn Brake Adjustment Screw counterclockwise with (-) screw driver.

(NOTE: The Brake is adjusted when shipped out of the factory so do not meddle with it.)

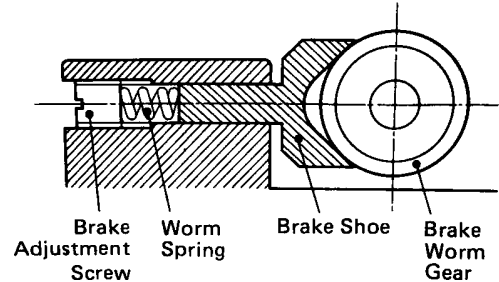

PROTECTOR

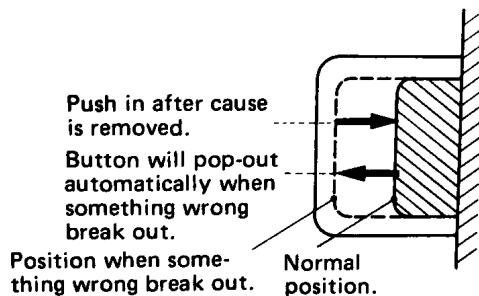

A Push Button Switch (Protector) is located on the left side of the Head Cover. If something is wrong with the blade section or the revolving section, the machine will automatically stop to prevent overheating and damage the motor. In such case, turn off the Power Source Switch (Disconnect the plug) and after the cause is removed. Plug in cord and push the protector. The Motor will automatically start again.

TO REPLACE DAMAGED PRONG

As the 4 Slotted screw heads as well as the seam between the plastic and the Ice Block Holder base plate is sealed with silicone, be sure to seal after the replacement.

TO MAINTAIN SANITATION WITHOUT TOOLS

For periodic cleaning of the Shaving Disc as well as adjacent area in the food zone, removal is possible as follows.

1. By removing the 4 thumb-screws located on the underside of the plate, the Shaving Disc can be easily removed by pushing it up.
2. To clean the Shaving Disc Frame and the adjacent area, remove the 4 thumb-screws holding the Front Cover (2 thumb-screws on each side), then pull the Front Cover towards the user to remove. The entire food zone can be easily cleaned.

REPLACEMENT BLADE

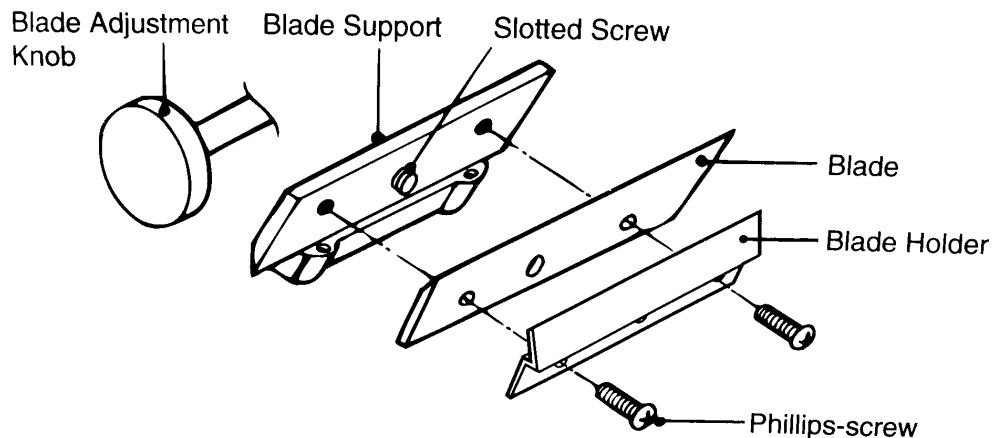

1. Turn the Blade Adjustment Knob right all the way until it stops.
2. Unscrew the two Phillips-screws. Remove the Blade Holder and blade. **IMPORTANT: DO NOT MEDDLE WITH THE CENTER SLOTTED SCREW.**
3. Place the new Blade accurately on the Standard Level Guide Screws on the Blade Support.
4. Put on the Phillips-screw and slowly screw it on so the blade will not life up from the Standard Level Guide Screws. Screw it on tight.

*If both ends of the Blade are not accurately set on the Standard Level Guide Screws, the ice will not shave satisfactorily. In such case, use something flat and lightly press down the Blade from the surface of the Shaving Disc, then tighten the Phillips-screws.

STORAGE AFTER SEASON

Wipe off moisture with piece of cloth, then wipe again with dry piece of cloth. Remove Blade, clean and lubricate with cooking oil, the wrap in oil paper before storage. Remove all soiled oil from the Main Shaft and lubricate with grease approved by FDA for the lubrication of food processing machinery. Do not use cooking oil.

*Specifications are subject to change without notice for further design and performance improvement.

SPECIFICATIONS

Dimensions:	25-3/4" high x 11-1/8" wide x 15-1/8" deep
Weight:	61.7 lbs.
Shaving Capacity:	4.84 to 5.5 lbs per minute
Motor:	115V, 200W
Power Requirement:	210W, 60Hz
Accessories:	Spare Blade (1), Grease oil (1), Drain Hose (1)

TROUBLE SHOOTING GUIDE

PROBLEMS		CAUSES		SOLUTION
DOES NOT MOVE	Motor fails to turn.	Cord	Cord not properly plugged in	Plug cord into socket properly
			Broker power cord	Replace power cord
	Main Shaft do not move up and down	Ice Block Holder Crank	Missing or broken Lock Pin for Ice Block Holder Crank	Install new Lock Pin
DO NOT SHAVE	Do not shave.	Blade	Chipped or rusty blade	Replace blade
	Ice block jump out or unsteady	Blade	Blade is raised higher on the inner side than the outer side of Shaving Disc. Blade is raised too high because blade does not shave.	Set Blade flush with Shaving Disc
		Brake	Tension adjustment of Brake too weak	Turn Brake Adjustment Screw clockwise to tighten
		Ice Block	Prongs not firmly imbedded in ice block	Turn over ice block so flat side is up
	Shave ice too fine	Blade	Blade not set properly or Blade is dull	Set Blade properly or sharpen Blade
		Brake	Tension adjustment of Brake too weak	Turn Brake Adjustment Screw clockwise to tighten
	Shave ice too rough	Blade	Blade raised too high because blade do not shave	Replace or sharpen blade
		Brake	Tension adjustment of Brake too strong	Turn Brake Adjustment Screw counterclockwise to ease
	Texture of shave is not uniform	Brake Worm Gear	Worn out case iron Brake Worm Gear	Replace Brake Worm Gear
		Brake Shoe	Weak or worn out Brake Shoe Spring	Replace Brake Shoe Spring
ICE BLOCK HODLER CRANK	Turns heavily	Brake	Brake tension too tight	Ease tension by turning Brake Adjustment Screw counterclockwise
	Turns lightly	Brake	Brake tension too weak	Tighten tension by turning Brake Adjustment Screw clockwise
		Brake Shoe	Weak or worn out Brake Shoe Spring	Replace Brake Shoe Spring

STERILIZATION

To maintain sanitation of the under mentioned parts, do not fail to sterilize in a sterilization solution.

- (12) BLADE (22) BLADE HOLDER (17) DRIP TRAY

❖ **EXAMPLE**

Put Blade, Blade Holder and screws inside the Drip Tray, then place this tray inside a vessel and pour in proper quantity of sterilization solution. We recommend this process be carried out after closing shop in preparation for the next day's work.

PARTS LIST

SWAN
ICE SHAVE NEW MODEL SI-100E (for Block Ice)

PARTS No.	PARTS NAME	MATERIAL	REMARKS
1	Main Shaft Handle	FC-20	
2	Gear Box Cap	FC-20	
3	Worm Gear	C5191-B	
4	Gear Box	FC-20	
5	Worm Gear Rubber	Rubber	
6	Brake Adjustment Hole Plug	Rubber	
7	Main Shaft	S35C-D	
8	Polycarbonate Shield	Polycarbonate	
9	Ice Block Holder Cover	AC4A	
10	Shaving Disc with Frame	AC7A	
11	Head Stock Under Cover	P.P.	
12	Blade	SUS	
13	Blade Support	BC	
14	Cutter Block Pin	Brass	
15	One Touch Spring	SUS304	
16	Blade Adjustment Knob	SUS304, ABS	
17	Drip Tray	ABS	
18	Motor Cover Rubber	Rubber	
19	Head Cover	ABS	
20	Motor	115V 60Hz	
21	Brake Worm Gear	FC-20	
22	Blade Holder	SUS304	
23	Head Stock	FC-20	
24	Main Frame Cover	ABS	
25	Frame	SS400	
26	Rear Guard F Stopper	SUS304	
27	Rear Guard M Stopper	SUS304	
28	Frame	SS400	
29	Front Panel	ABS	
30	Base	FC-20	
31	Rubber Feet	Rubber	
32	Gear Box Rubber	Rubber	
33	Switch Cover	Rubber	
34	Protector	OR-627	
35	Motor Switch	Fuzisoku ET115A	
36	SS Worm	S45-C	
37	Brake Shoe Bracket	FC-20	
38	Worm Spring	SWP	
39	Brake Shoe	BC	
40	Worm Shaft Bracket	FC-20	
41	Ice Block Holder Crank	FC-20	
42	Ice Block Holder	Duracon. SUS	
43	Grease Oil	Grease Oil	
44	Plug	W/C Cord	
45	White Thumb Screws Long/Short	SS. ABS	
46	Drain Hose	PVC	

